



ShowerPan

Model #PS-3060L-W, PS-3060R-W
PS-3260L-W, PS-3260R-W

PW-93060L-89W, PW-93060R-89W
PW-93260L-90W, PW-93260R-90W

Owner's Manual



Please Read The Following Instructions COMPLETELY Before Beginning!

Our goal is to ensure your installation goes smoothly and safely. Please read these instructions carefully and follow recommendations for plumbing and mounting. After reading instructions, if you determine you do not have the necessary skills and/or tools, we recommend that a licensed plumbing contractor complete the installation.

If you encounter any problems during installation
PLEASE VISIT CUSTOMER SUPPORT AT
WWW.PULSESHOWERSPAS.COM
Before returning your ShowerPan to the store

You Will Need The Following Tools

Soft pencil to mark placement

Adhesive or Mortar

Level

Safety Glasses

Measuring Tape

Screwdriver

Rubber Mallet or Hammer

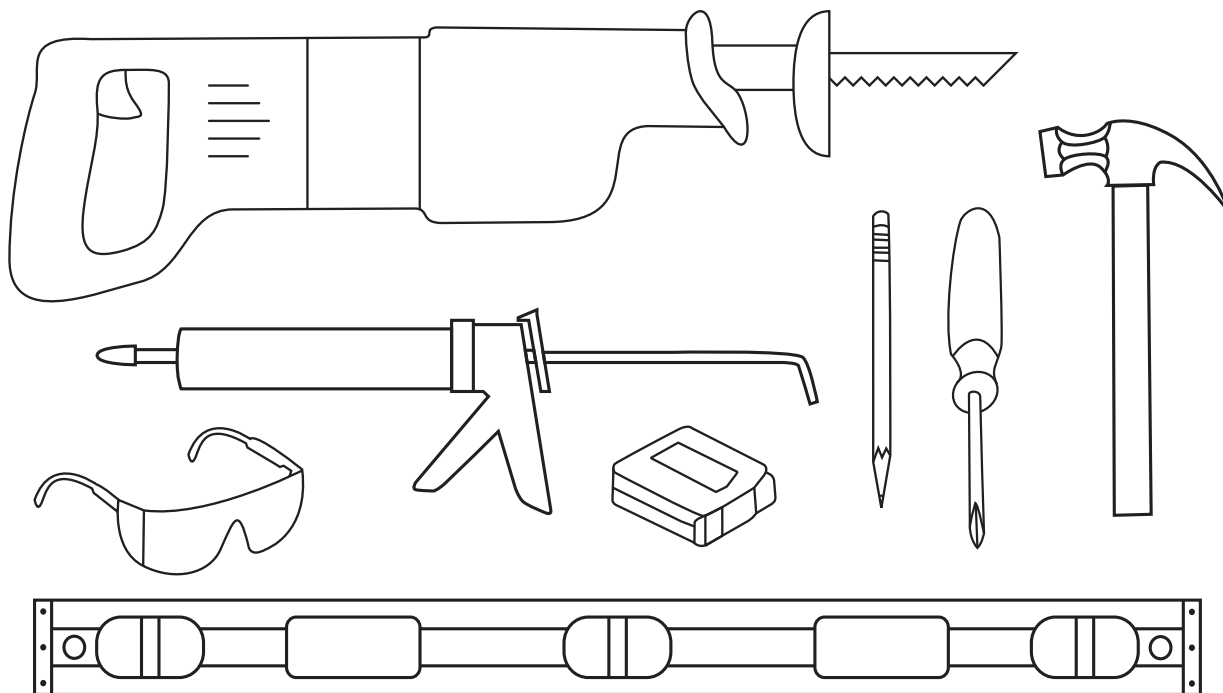

Parts Legend

1. ShowerPan

2. Support Rods

3. Drain

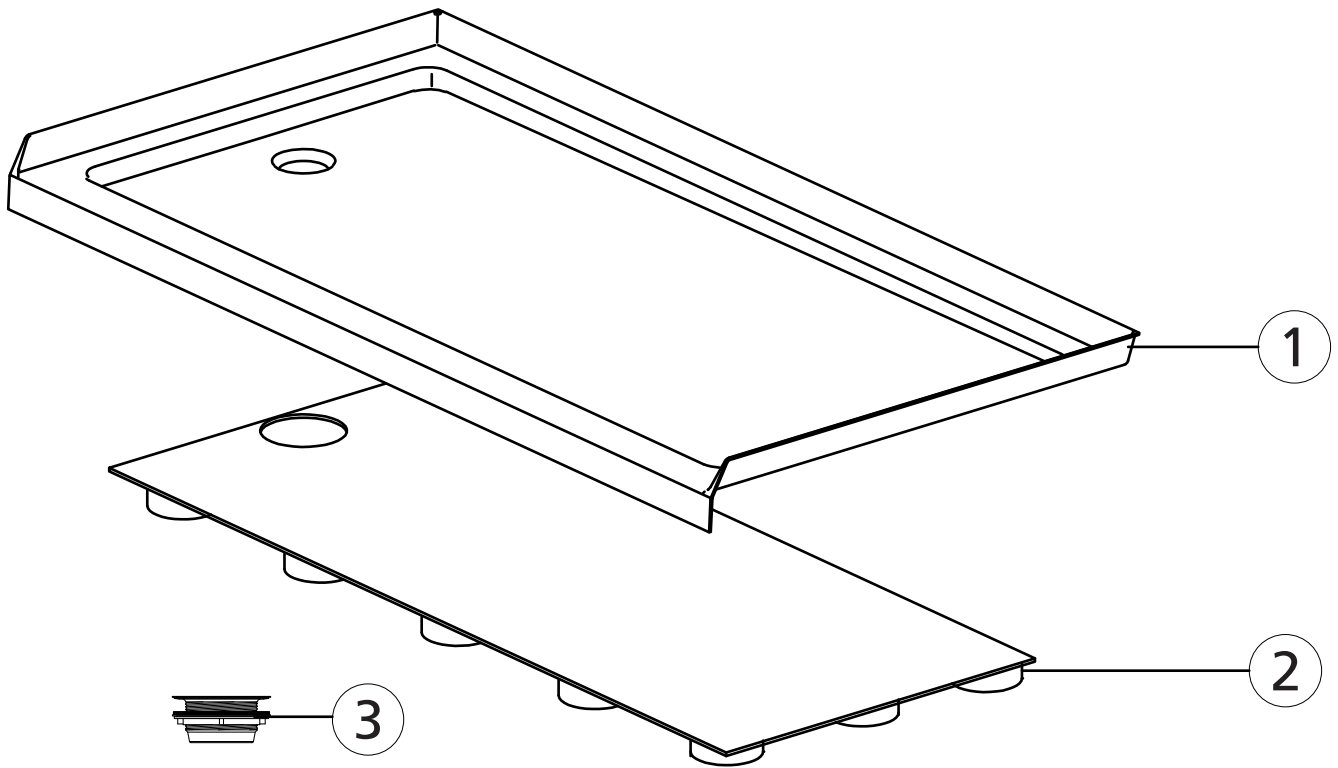

Installation Instructions

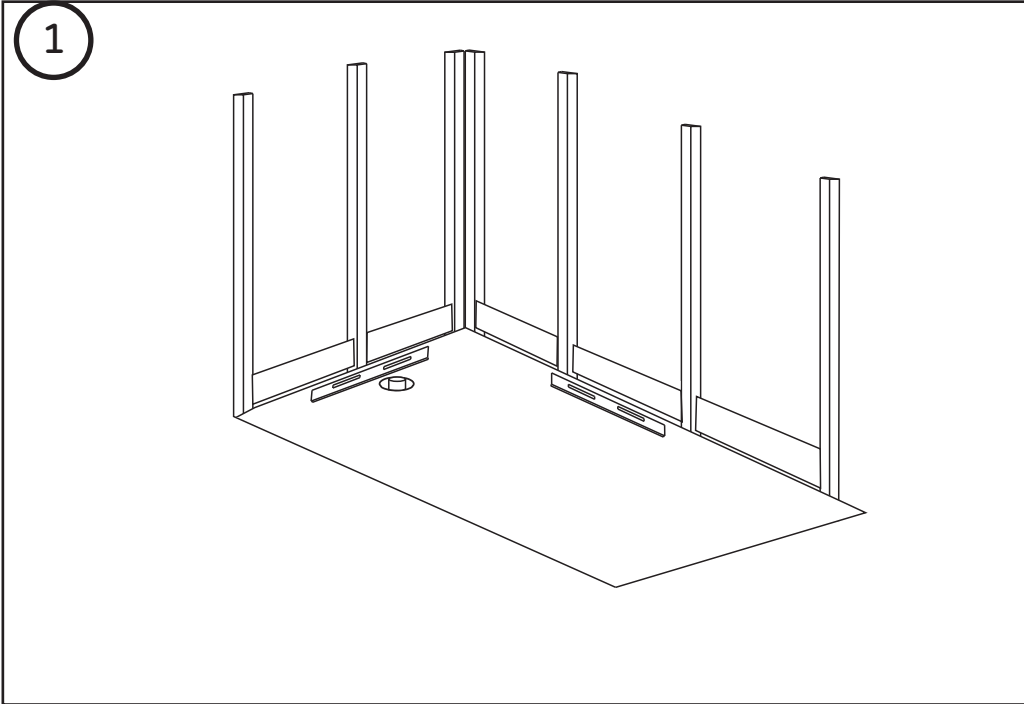

Prepare the Floor: Ensure that the floor where the shower pan will be installed is clean, level, and free of debris. If necessary, repair any cracks or damage to the floor before proceeding.

Install the Drain Assembly: Attach the drain flange to the floor and connecting it to the drain pipe. Use a rubber gasket or shower liner to create a waterproof seal around the drain.

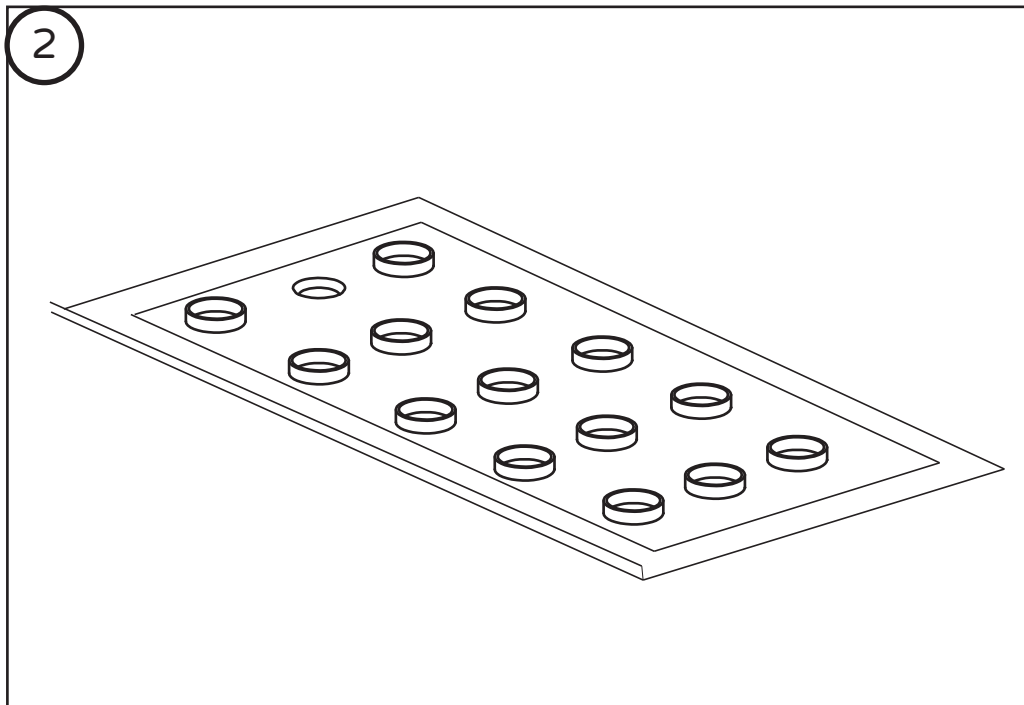

ShowerPan back side

Connect the Drain: Attach the shower pan's drain outlet to the drain assembly. This may involve using adhesive or sealant to create a watertight seal.

Installation Instructions

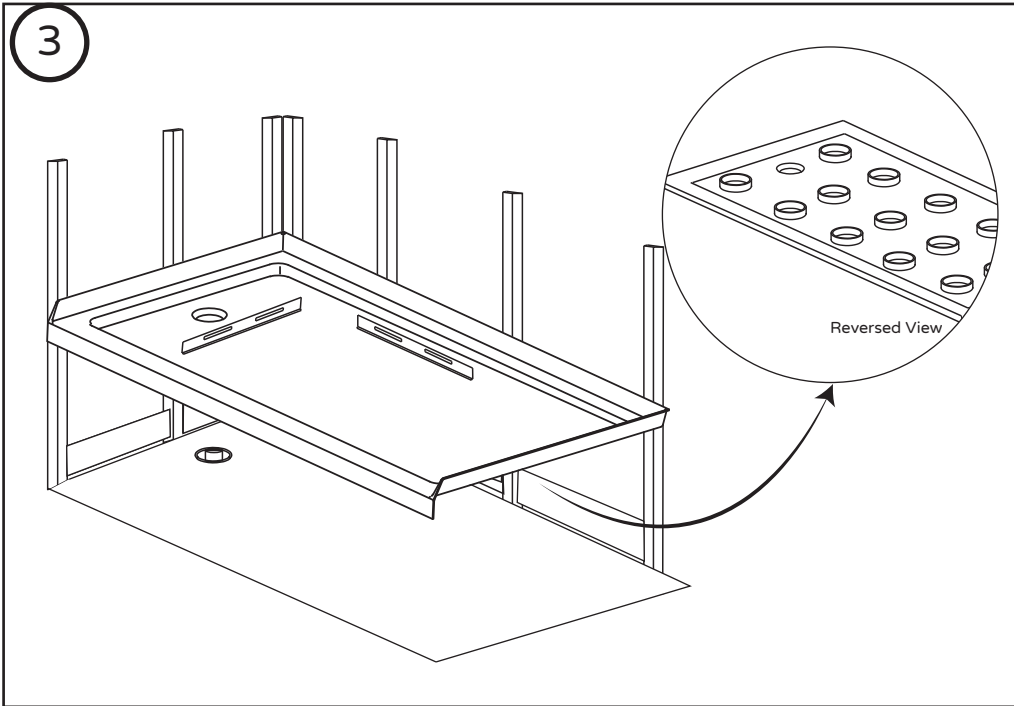

Position the Shower Pan: Place the shower pan on the floor, ensuring that it is centered and level. Use a level to check that the pan is level in all directions.

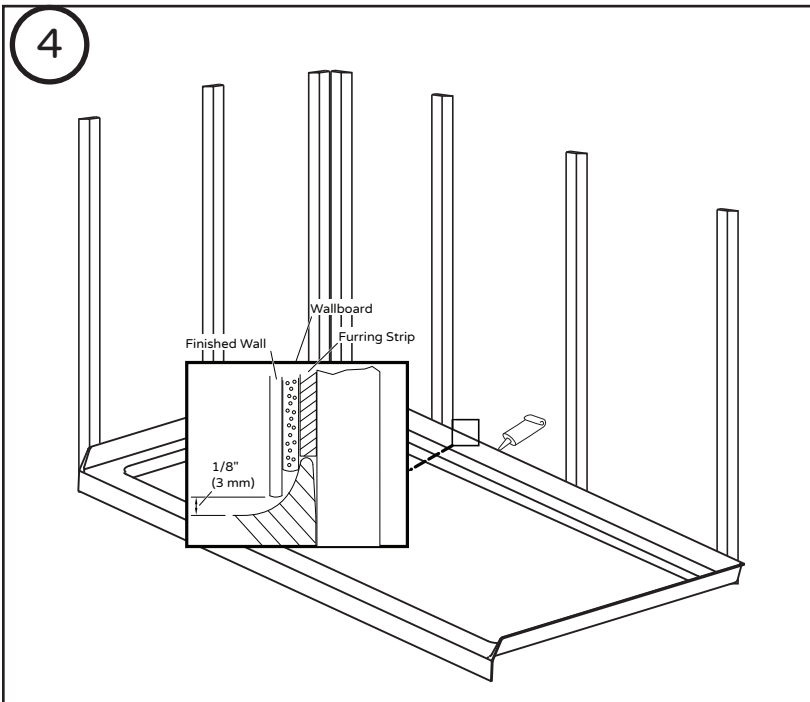

1. Use furring strips to make the framing flush with the flanges
2. Install water-resistant wallboard
3. Install the finished wall to within 1/8" (3mm) of the rim
4. Apply 100% silicone sealant around the shower base where it contacts the finished walls
5. Install the finished floor. Apply 100% silicone sealant along the floor seam

Installation Instructions

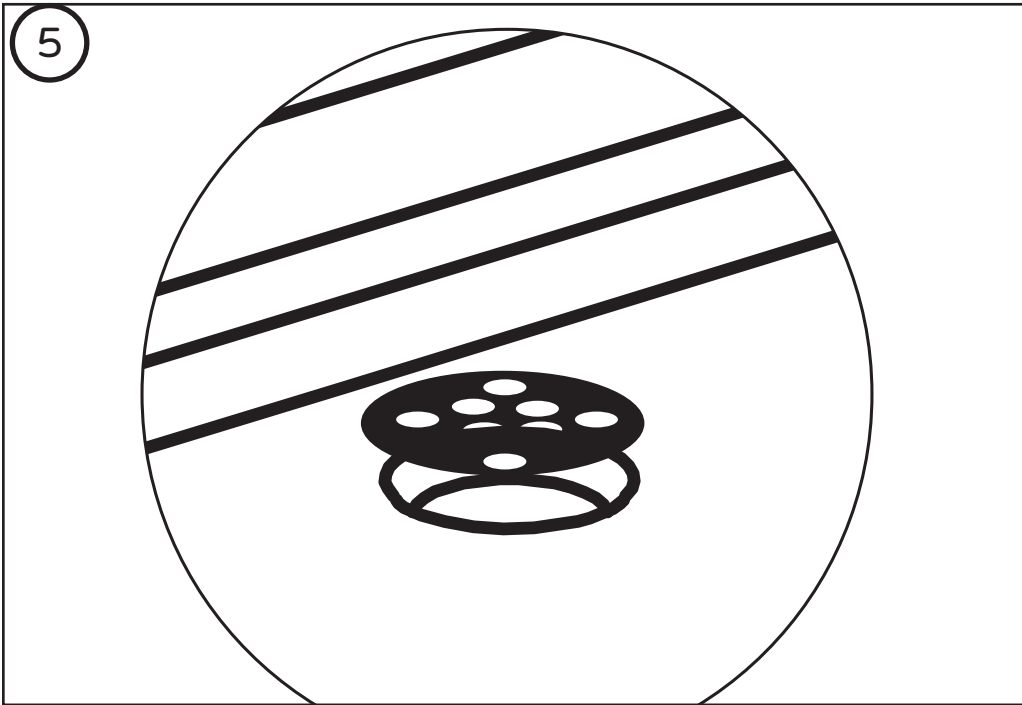

Connect the Shower Drain Cover:
Install the shower drain cover.

Test for Leaks: Fill the shower pan with water and check for any leaks around the drain and the edges of the shower pan. If any leaks are detected, address them promptly by resealing or tightening connections as needed.

Complete the Shower Installation:
Once the shower pan is securely installed and there are no leaks, you can proceed with the rest of your shower installation, including installing the shower walls, fixtures, and finishing touches.

MANUFACTURER'S LIFETIME LIMITED WARRANTY

1. Defects Covered; Warranty Period: Pulse Shower Spas, Inc. ("Pulse") warrants to the original consumer purchaser who purchases this shower spa (the "Product") for use in his or her own home, that the Product will be free from defects in material and manufacturing workmanship for as long as the original consumer purchaser owns that same home. For all other purchasers (including, but not limited to purchasers for industrial, commercial and business use), the above warranty will apply for a period of 5 years from the original date of purchase.

2. Remedy: If the Product does not conform to the above warranty, Pulse, at its option, will repair or replace the Product, free of charge, or refund your purchase price. For warranty claims, please visit www.pulshower spas.com/index.php/warranty. Pulse may require that you return the Product to Pulse, shipping prepaid, in which case Pulse will provide you with a return materials authorization number (RMA). Pulse may also require that you provide evidence of the date you purchased the Product. Pulse will ship a new or repaired Product to you, at the expense of Pulse, or refund your purchase price. Service labor performed by you or others in connection with the removal or replacement of the Product will not be reimbursed by Pulse.

3. Exclusions: Pulse shall not be responsible for failure of the Product, and the above warranties will not apply, if the Product fails as a result of improper installation, improper use, modifications or repairs by anyone other than Pulse, or accident or abuse (including damage during shipment).

4. Warranty on Repairs and Replacements: For consumer purchasers who purchased the Product for home use, repaired or replacement Products will continue to be covered under this warranty for as long as he or she owns that same home. For other purchasers, repaired or replacement Products will be covered for the balance of the original warranty period.

5. No Other Warranties; Limitation of Liability: OTHER THAN THE LIFETIME LIMITED WARRANTY STATED ABOVE, PULSE DISCLAIMS ALL OTHER WARRANTIES, EXPRESS OR IMPLIED, INCLUDING BUT NOT LIMITED TO WARRANTIES OF MERCHANTABILITY AND FITNESS FOR A PARTICULAR PURPOSE, TO THE EXTENT PERMITTED BY APPLICABLE LAW. THE REMEDIES STATED ABOVE ARE YOUR SOLE REMEDIES IN CONNECTION WITH THIS WARRANTY. IN NO EVENT WILL PULSE BE LIABLE TO YOU FOR ANY DAMAGES, WHETHER DIRECT, INDIRECT, INCIDENTAL, SPECIAL OR CONSEQUENTIAL, INCLUDING BUT NOT LIMITED TO LOST PROFITS OR BUSINESS INTERRUPTION, ARISING OUT OF OR RELATING TO THE PRODUCT OR ITS USE, WHETHER UNDER A CONTRACT, WARRANTY, TORT, OR ANY OTHER CAUSE OF ACTION, EVEN IF PULSE HAS BEEN ADVISED OF THE POSSIBILITY OF SUCH DAMAGES. NOTWITHSTANDING THE TERM OF ANY LIMITED OR IMPLIED WARRANTY, OR IN THE EVENT THAT ANY LIMITED WARRANTY FAILS OF ITS ESSENTIAL PURPOSE, IN NO EVENT WILL PULSE'S ENTIRE LIABILITY EXCEED THE PURCHASE PRICE OF THE PRODUCT. SOME STATES AND PROVINCES DO NOT ALLOW THE EXCLUSION OR LIMITATION OF INCIDENTAL OR CONSEQUENTIAL DAMAGES SO THE ABOVE LIMITATIONS OR EXCLUSIONS MAY NOT APPLY TO YOU. THIS LIMITED WARRANTY GIVES YOU SPECIFIC LEGAL RIGHTS, AND YOU MAY ALSO HAVE OTHER RIGHTS WHICH VARY FROM STATE TO STATE AND PROVINCE TO PROVINCE.

NOTES

